

OPERATING INSTRUCTION MANUAL
FOR
OPTICAL INTERFEROMETIC GAS ANALYZER
MODEL FI-800

FOR USERS

Safety Precautions

1. Read and understand the instructions in this manual before operating this instrument.
2. Keep manual accessible at all times.
3. This instrument cannot be used for any other purpose than what is specified in this manual.
4. Follow all the instructions in this manual, an deviation will compromise the safety, quality and performance of this instrument.
5. We accept no responsibility for an accident caused by the user not following the instructions in this manual.



RIKEN KEIKI CO., LTD.

2-7-6 Azusawa Itabashi-ku Tokyo, 174-8744 Japan

Phone : 81-3-3966-1113
Fax : 81-3-3558-9110 GIII
E-mail : intdept@rikenkeiki.co.jp

Introduction

Thank you for purchasing our optical interferometric gas analyzer Model FI-800.

This is a fixed type explosion proof (Exd II B + H2T4) gas analyzer to measure various gas concentrations such as 「Hydrogen in Nitrogen」, 「Propane in air」, 「Toluene in air」, etc and gas calorie continuously. To use FI-800 correctly, correct installation, wirings and pipings are required. Before using FI-800, confirm that the construction works have been performed in accordance with 「Installation work manual」.

This manual is a guidebook for use of the FI-800. All persons who use this analyzer for the first time and who has ever used the analyzer are requested to read through the manual to understand the content before use.

This manual contains the following headings to ensure the safe and effective operation.



Means vital damage directly to the human life and body or properties due to contact with high voltage, etc.



Means vital damage to the human body or properties unless the operation or measures of this manual are observed.



Means minor damage to the human body or properties unless the operation or measures of this manual are observed.

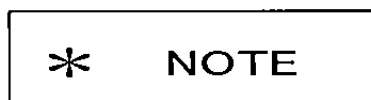

Means advice concerning handling and operation.

1. Function of the product

1-1. Overall view and accessories

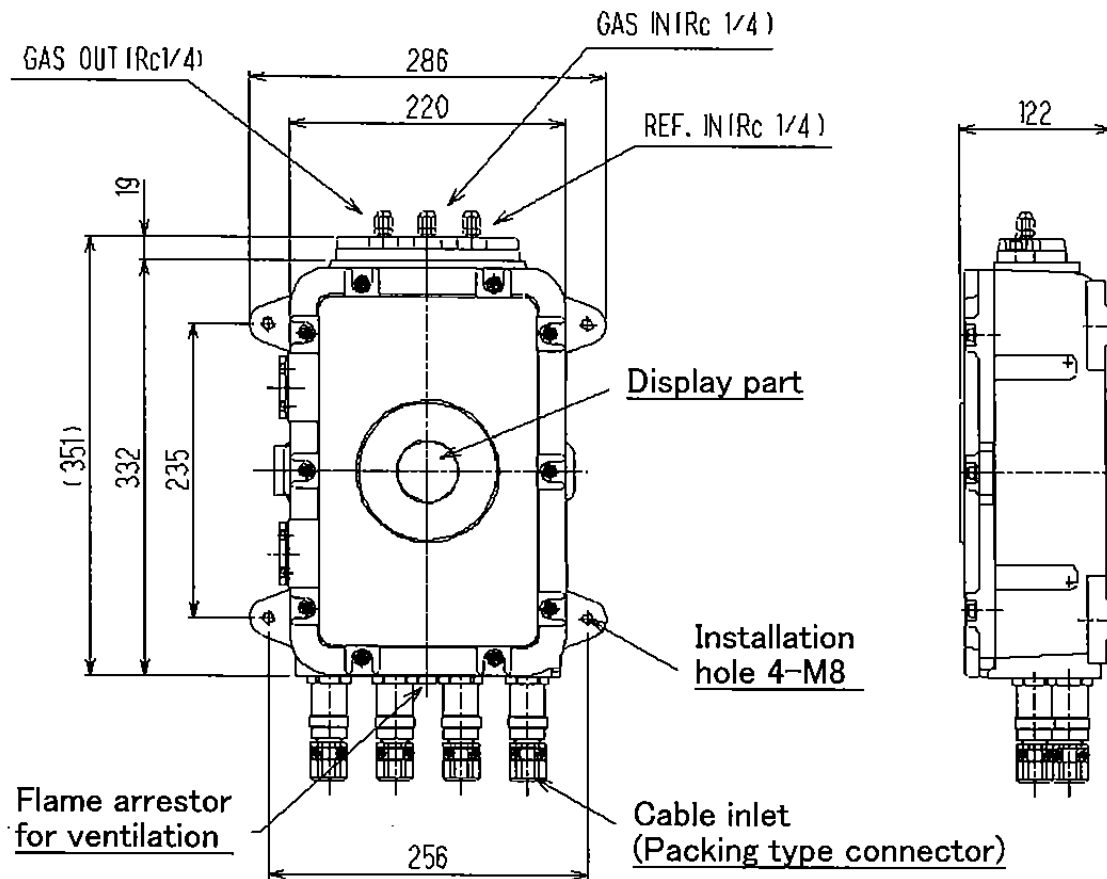

- * Quantity to be used with packing type connector, kind of packing and inner diameter of packing subject to customer's application for use.

Accessory : Control key



! WARNING

The control key used for adjustment is made from a powerful magnet. If it is closed to a credit card, ID card, other magnet products, this key may damage the stored data.

1-2. Name of display part and functions

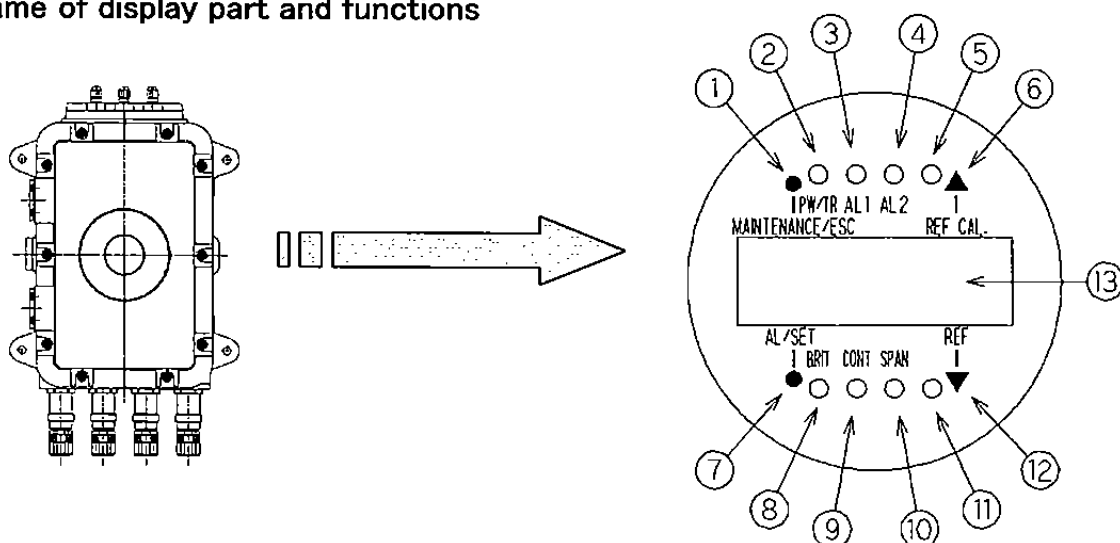

- ① MAINTENANCE/ESC switch Used for entering into the maintenance mode with the control key. [Used to cancel the maintenance mode.]
- ② PW/TR light Illuminates continuously when the equipment is working
(power light). And flickers in the case of abnormality in the equipment.
- ③ AL1 light Illuminates when 1st alarm is activating.
- ④ AL2 light Illuminates when 2nd alarm is activating.
- ⑤ R.CAL light Illuminated during reference gas calibration is performed.
- ⑥ REF CAL./UP switch Used to perform the reference gas calibration. [Used to increase the value.]
- ⑦ AL/SET switch Used for confirmation of preset alarm level. [Used for decision in the maintenance mode.]
- ⑧ BRIT light Illuminates when light source amount of interferometric sensor is displayed. Flickers when light source amount is decreased.
- ⑨ CONT light Illuminate when contrast of interferometric sensor is displayed. Flickers when contrast is decreased.
- ⑩ SPAN light Flickers in the span adjustment mode. Steady light when the adjustment is over.
- ⑪ REF. light This is not used in standard spec.(Option)
- ⑫ REF. /DOWN switch This is not used in normal measurement.(Option) [Used to decrease the level]
- ⑬ LCD Indicates the gas concentration and error code.

* Descriptions in [] show actions at maintenance mode.

All switches described in the above list are operated by control key. The switch is actioned by putting the control key onto ●mark or ▼▲mark for few seconds.

All descriptions of 「Press ○○○switch」 in this manual mean that the control key is put onto ●mark or ▼▲mark.

2. Operation method

2-1. Start-up method

Before start-up FI-800, confirm that the correct pipings and wiring works are performed.
(Refer to the separate manual 「Installation work manual」 for details.)

- (1) Confirm that the power is not supplied to the unit and remove 10 hexagonal socket headed bolts and lid. Turn ON the power switch inside the unit. In this case, the LED and LCD do not go ON because the power is not supplied to the unit.

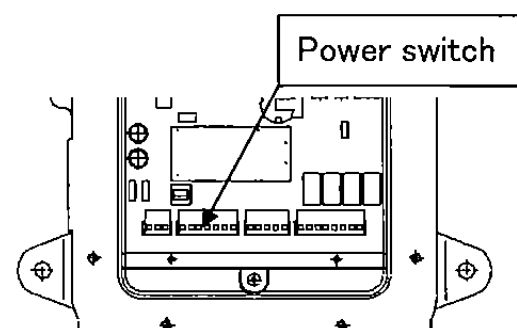

WARNING

When removing the front lid while the power is supplied, stop to supply measuring gas and confirm that there is no combustible gases around the unit beforehand.

- (2) Install the lid and 10 hexagonal socket headed bolts.
Tighten these bolts firmly and supply power to the unit.
- (3) With power ON to the unit, the “PW/TR” LED light goes ON and selfdiagnostic function starts.
- (4) After the unit becomes measurement mode without abnormality in the course of selfdiagnosis, adjust the sample flow rate.
- (5) Connect pipes for sample gas to GAS IN and reference gas to REF IN respectively.
When 3-way cock etc. is installed separately, change the cock position to supply the gas.
(See 「Installation work manual」 for piping method using 3-way cock).
- (6) Adjust sample flow rates of sample gas and reference gas to $300\text{ml} \pm 25\text{ml}/\text{min}$ respectively with flowmeter installed outside.
- (7) Change the position of 3-way cock etc. to supply reference gas to both GAS IN and REF IN.
- (8) Sample flow rate of reference gas to GAS IN shall be adjusted to the same flow rate as to supply the sample gas.
- (9) After reading gets stable (approx. 60 sec.), press REF CAL switch for about 5 seconds to make reference gas calibration.
- (10) After completion of reference gas calibration, return the cock position to supply sample gas to the GAS IN.

After completion of steps (1) to (10), continuous measurement is started..

2-2. Reference gas calibration

The reference gas calibration means the adjustment method of the reading to actual concentration (reference gas concentration) by supplying reference/substitute gas instead of measuring gas. Generally, the gas to show 0% by volume or 0% LEL is used as reference gas and this is the same meaning of zero adjustment. Make reference gas calibration from time to time.

Reference gas calibration is done with following procedures.

- Supply reference gas to both GAS IN and GAS OUT by changing the position of 3-way cock etc. which is installed outside.
- Wait until the reading gets stable and check that it shows the correct concentration(Reference gas concentration).
- If reading is different, press ▲mark of REF CAL for about 5 seconds.
- REF CAL light flickers for about 10 seconds and then, shows reference gas concentrations.

* NOTE

There is a case to use the reference gas to show 100 vol.% or exception of 0% depending on the specifications of FI-800.

Confirm relations between 「reference gas」 and 「reference gas concentration」 with 「Specifications for measuring gas」 prepared separately.

2-3. Gas alarm action

The FI-800 provides three alarm patterns such as 「H, HH alarm」, 「L, LL alarm」 and 「L.H. alarm」.

Each alarm action has the 1st alarm point(AL1) and the 2nd alarm point (AL2) which are activated when below conditions are covered.

The mark X in below table means gas concentrations.

Alarm pattern	1 st alarm condition	2 nd alarm condition
H, HH alarm	$X \geq AL1$	$X \geq AL2$
L, LL alarm	$X \leq AL1$	$X \leq AL2$
L, H alarm	$X \leq AL1$	$X \geq AL2$

When measuring gas concentration levels meet with the 1st alarm condition, relay contact for outer alarm works and AL1 light flashes.

But measuring gas concentration levels become out of the 1st alarm condition, relay contact for 1st alarm is reset and AL1 light turns off automatically (Self-reset).

2nd alarm provides same pattern as for 1st alarm.

Confirmation method for alarm pattern and alarm preset levels are described in chapter 「3-4 Checking of preset alarm levels」

**CAUTION**

b-contact(Break contact) at non-exiting condition may change to open contact

in a moment due to physical shock.

Whenever alarm signals are used with b-contact(option), please put delayed circuit(for about one second) to receiver side of b-contact to avoid such phenomenon.

2-4. Checking of preset alarm levels

Press ●mark of AL/SET switch by control key for more than 5 seconds. When the switch is being pressed, 「Alarm pattern」, 「1st alarm level」 and 「2nd alarm level」are indicated by turns in every 1 second on LCD (See below fig.).

When 1st alarm point is indicated, AL1 light is lighting, AL2 light is keep lighting when 2nd alarm point is indicated.

When releasing the control key, they return to concentration display.

To change AL1 and AL2, please see 「3-6 Setting of alarm levels」 in maintenance mode.

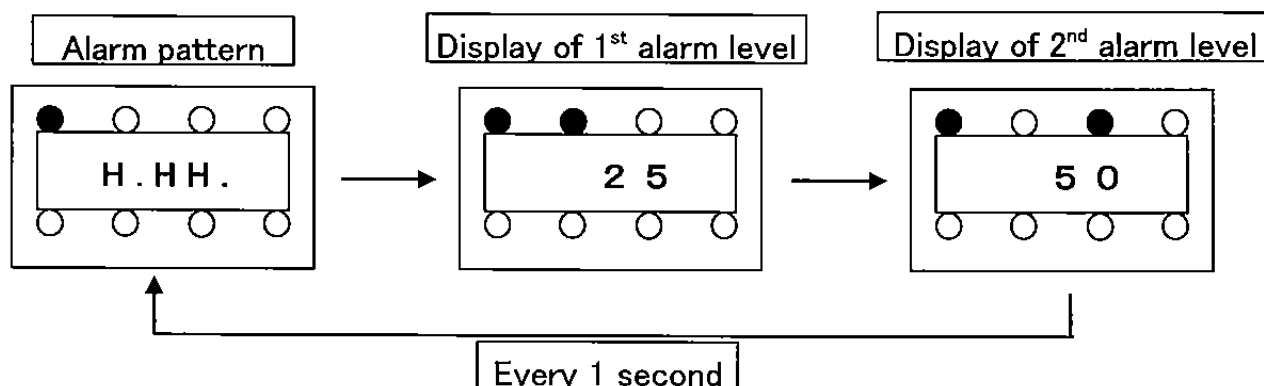
**2-5. Cautional display for sensor deterioration**

When detecting sensor deterioration during selfdiagnosis or measurement, BRIGHT light and/or CONT light flashes to show the deterioration of the sensor.

Flashing of BRIGHT light

This is a cautional indication for the decrease of light amount. This means the decrease of light amount for the light source of interferometric sensor. Recommend to replace or repair the interferometric sensor before interruption of measurement.

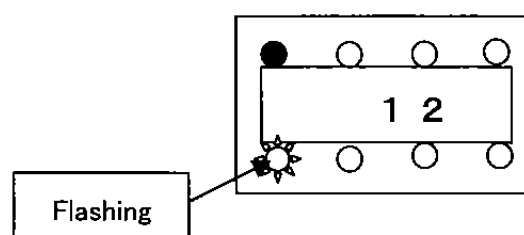
Flashing CONT light

This is a cautional indication for the decrease of contrast. This means that the interferometric sensor is being dirty. Recommend to replace or repair it before interruption of measurement.

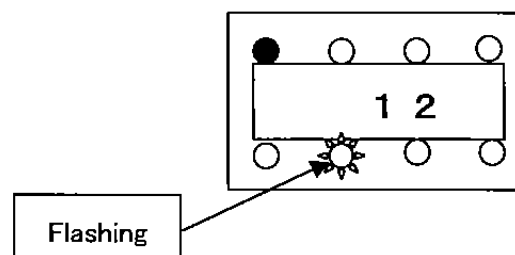
**2-6. Trouble indications and countermeasures**

When the abnormality is detected during selfdiagnosis or measurement, PW/TR light flashes and relay contact for trouble alarm works.

In this occasion, error code number is displayed and outputs for 4-20mA is fixed at 0.5mA.

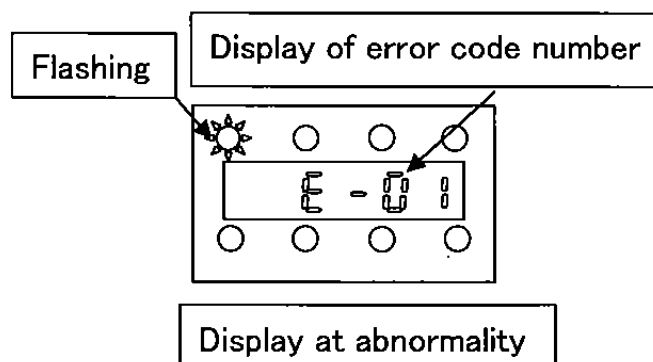

Make necessary countermeasure if error code number is displayed.

Contents of error code and countermeasures

Error code	Contents and countermeasures
E-00	This means the abnormality of the system. Replacement/repair of main PC board is required
E-01	This means the interruption of measurement due to the deterioration of inteferometric sensor. Flashing of BRIGHT light means the decrease of light amount for light source remarkably and flashing CONT light means the decrease of contrast remarkably. In any case, replacement/repair of interferometric sensor is required.
E-02	This means the possibility of damage for setting data of measuring gas or reference gas, a damage for alarm level or sensor sensitivity data being set at maintenance mode. Re-setting for various data or replacement/repair of main PC board is required.
E-05	This means that the sample flow rate for sample gas or reference gas to be supplied from GAS IN or REF IN is zero. It is thought that external pump, aspirator or reducing valve is defective or pipings are blocked.

3. Operation method in maintenance mode

3-1 Maintenance mode and summary of each menu.

Maintenance mode of FI-800 is to make 「Confirmation of the status for interferometric sensor」, 「Adjustment of 4~20mA output」 「Adjustment of sensor sensitivity」, 「Setting of alarm levels」 etc.

Pressing ●mark of MAINTENANCE switch for above 5 seconds during measurement mode, it is entered to maintenance mode.

Pressing ●mark of MAINTENANCE switch again for above 5 seconds, it changes to the normal measurement mode.

Once maintenance mode is entered, analog output becomes approx. 2.5mA and REF CAL light flashes.

Also, the menu shown at right side is displayed on LCD display part.

You can step to each menu by pressing UP/DOWN switch ▼/▲ and ●mark of SET switch.

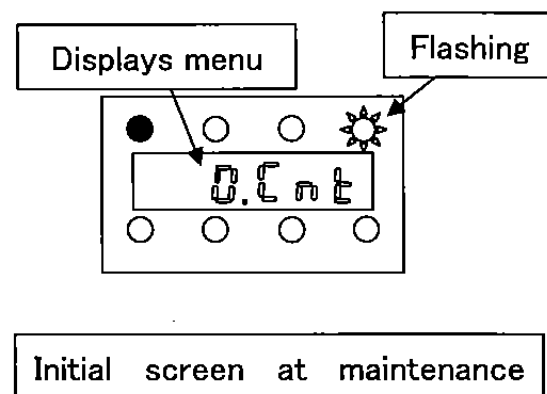

The below table shows each menu and its contents.

LCD display	Contents of menu
0.000	Display of contrast for interferometric sensor
1.000	Display of light amount for interferometric sensor
2.000	Adjustment of 4~20mA output
3.500	Adjustment of sensor sensitivity (SPAN)
4.000	Setting of alarm levels.
5.000	Alarm test
6.000	Setting of CAL cycle for AUTO REF (Option)
7.000	Display of ROM number
8.000	Display of specification number
9.000	Pressure display at sensor part
0.000	Temperature display

3-4. Adjustment of 4~20mA output

Pressing SET switch while 2.000 is displayed, 4mA test signal is output as shown right figure.

Pressing ▲▼switch, it changes to 20mA output.

When SET switch is pressed during 4mA or 20mA test signal output, LCD flashes and signal level can be adjusted with ▲▼switch.

Press SET switch to enter adjusted level.

Pressing ●mark of MAINTENANCE switch, it returns to 2.000.

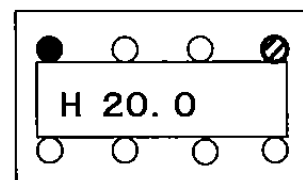
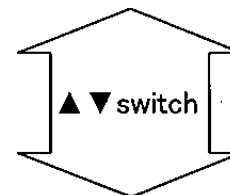
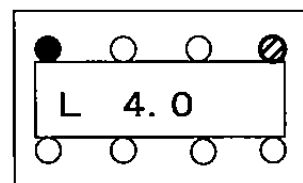

エヲ

* NOTE

4-20mA output is adjusted before shipment. However, zero or full scale value may be changed slightly due to the condition of receiver side like recorder etc.

In such case, adjust output according to this step.

3-5. Sensitivity (Span) adjustment of the sensor.

The measurement result of the gas to be supplied from GAS IN is displayed when SET switch is pressed during

3.5 Pn is displayed

Pressing SET switch again, LCD flashes and SPAN LED turns on to show that the span adjustment is ready.

Supply pre-known standard gas and adjust indication with ▲▼switch.

Press SET switch to enter the adjusted value.

Pressing ●mark of MAINTENANCE switch, it returns to 3.5 Pn.

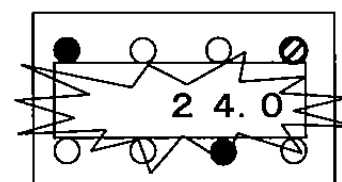
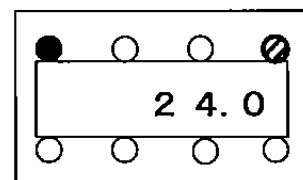

Adjust sensitivity during LCD is flashing, enter with SET switch.

! WARNING

Before making sensitivity adjustment, be sure to make calibration by reference gas (See step 2-2).

Calibration by reference gas is done in measurement mode.

3-6. Setting of alarm levels

Pressing SET switch during  is displayed, the alarm pattern of FI-800 is displayed.

Under this condition, the 「1st alarm level」 and 「2nd alarm level」 are shown with ▲▼switch.

AL1 light and AL2 light turn on for 「1st alarm level」 and 「2nd alarm level」 respectively. Pressing SET switch during 「1st alarm level」 or 「2nd alarm level」 is displayed, LCD flashes and it is possible to change the setting with ▲▼switch.

Pressing ●mark of MAINTENANCE switch, it returns to .

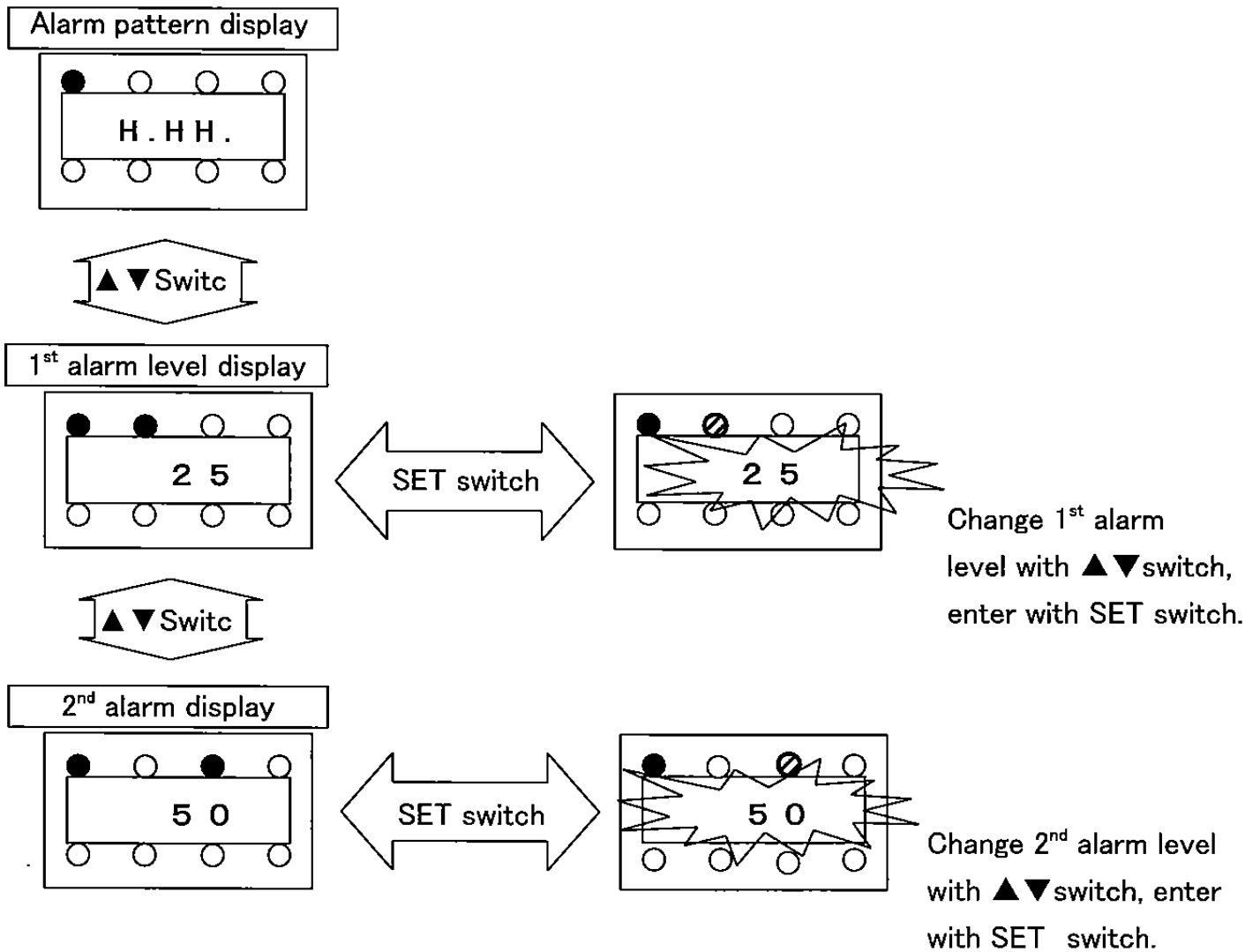

3-7. Alarm test

It is possible to confirm alarm functions of this analyzer.

**CAUTION**

When make alarm(transmission) test, announce it to respective department beforehand as this analyzer has an alarm contact. Carry it out after making proper treatment (external signal output, alarm contact).

- ① Press SET switch during S.t S.t is displayed.
- ② Select the working of alarm contact with ▼ ▲ switch and enter it with SET switch.
L.O F F (Not working) ⇔ L. 0 0 (Working)
- ③ When alarm test mode is started, test level(zero level) on LCD display flashes. If alarm contact is set to L. 0 0, both CONT light and SPAN light flash.
- ④ It is possible to change the test level between 0~full scale or over scale by pressing ▲ switch or ▼ switch.
 (4~20mA output level will be changed according to indication)
- ⑤ The 1st alarm will activates when test level reaches to 1st alarm level.
 (After passing alarm delay time, AL1 light flashes and 1st alarm contact will work if it is set to L. 0 0)
- ⑥ The 2nd alarm will activates when test level reaches to 2nd alarm level.(After passing alarm delay time, AL2 light flashes and 2nd alarm conduct will work if it is set to L. 0 0 .

Pressing ● mark of MAINTENANCE switch, it returns to S.t S.t .

3-8. Setting of AUTO REF CAL CYCLE(Optional)

Pressing SET switch during  is displayed, auto reference calibration cycle is displayed. This is an optional function. The FI-800 which has no optional function is set to 「ACC.0」.

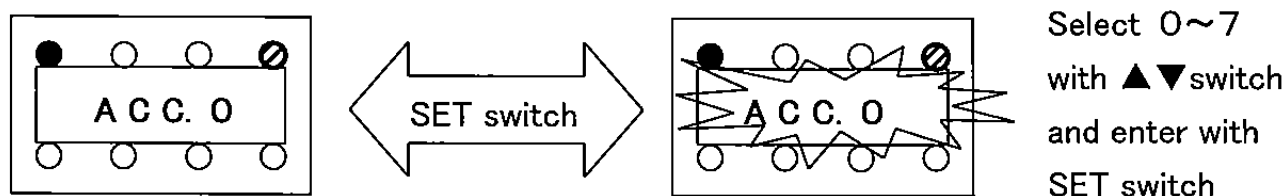

WARNING

It is required to make exclusive piping and wiring construction to use the function of auto reference calibration.

Be sure to set to 「ACC.0」 if this function is not used. If incorrect setting is made, zero level goes down minus side and normal measurement cannot be performed

3-9. Display of ROM number

Pressing SET switch during  is displayed, program number (our control No.) and sum level in FI-800 are shown one after the other.

This function is to confirm by field service engineer and is not important function for user.

Pressing ●mark of MAINTENANCE switch, it returns to .

3-10. Display of specification number

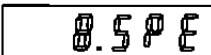
Pressing SET switch during  is displayed, specification number (our control No.) of FI-800 is displayed.

This function is to confirm by field service engineer and is not important function for user.

Pressing ●mark of MAINTENANCE switch, it returns to .

3-11. Pressure/temperature display in sensor part.

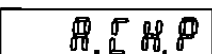
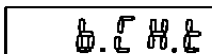
Pressing SET switch during  or  is displayed, gas pressure (kPa, Absolute pressure) or temperature (°C) around sensor part is displayed.

4. Maintenance and inspection

This analyzer is used to operate continuously for a long time. To keep the sufficient performance, regular inspection is required.

— Maintenance contract —

It is recommendable to make maintenance contract for regular inspection, adjustments, repairing including gas calibration to maintain stable operation and sensitivity.

Please contact with our nearest agent for details of maintenance contract.

4-1. Inspection frequency and items

Following four frequent inspections are required.

- * Daily inspection By user
- * Monthly inspection By user
- * Every 6 months/12 months By manufacturer or authorized service engineer

<Daily inspection>

Item	Judgement
Confirmation of "PW/TR" LED light	"PW/TR" LED light is continuously ON during normal operation. Light OFF or flashing condition means the occurrence of trouble. Countermeasure in accordance with "Trouble shooting."
Confirmation of indication	When minus indication or abnormal indication is displayed, check the reference gas value and make "Reference gas calibration."
Confirmation of sample flow rate to "GAS IN" and "REF IN"	Check that 300 ± 25 ml/min is supplied to both "GAS IN" and "REF IN." If not, adjust it to 300 ± 25 ml/min respectively. Also check the value of other flowmeter and pressure gauge for external pipings.
Confirmation of "CONTRAST" LED light and "BRIGHT" LED light	These lights are turned off in normal condition. Flashing of these lights mean that the deterioration of interferometric sensor is progressing. It is progressed further, the analyzer becomes in trouble and measurement cannot be done. Replace interferometric sensor before troubling.

<Monthly including daily inspection>

Item	Countermeasure
Confirmation of reference gas level	Supply reference gas from GAS IN by changing the external 3-way cock position and confirm that the reference gas level is indicated. If not, make "Reference gas calibration."
Confirmation of deterioration for interferometric sensor	Make displays of contrast and light amount for interferometric sensor. Guess the deterioration speed and replacement time by comparing with past inspection data.
Confirmation of alarm action	Confirm that alarm light turns on and alarm contact works by making alarm test.

<Every 6 months/12 months inspection>

Item	Countermeasure
Gas sensitivity adjustment (Calibration)	After making reference gas calibration, supply the pre-known calibration gas from GAS IN and confirm that it shows correct indication.

Daily inspection and monthly inspection are included in 6 months/12 months inspections.

Following inspections are also done as occasion demands.

- ①Cleaning ②Replacement of parts ③Replacement of piping materials
④Confirmation of functions ⑤Others

**WARNING**

This analyzer may measure dangerous gases such as explosive gases & vapors continuously for a long period. To keep safety, be sure to make 「6 months/12 months inspections」

*** NOTE**

When make gas calibration or alarm test, announce it to respective department beforehand.

4-2. Replacement of fuse

⚠ CAUTION

When open the lid, make it after 30 seconds from powered off as electric charge may be accumulated in capacitor inside analyzer.

⚠ CAUTION

When open the lid, stop to supply measuring gas beforehand.

- (1) Stop the power supply to this analyzer.
- (2) Remove hexagon headed bolts(10pcs.), and open the lid. Remove fuses from fuse holders(2 pcs) on PCB as shown right figure.

- (3) Mount new fuses(2A, normal fusing).
After confirming that the power switch is ON, mount the lid and tighten it firmly with bolts (10 pcs.).

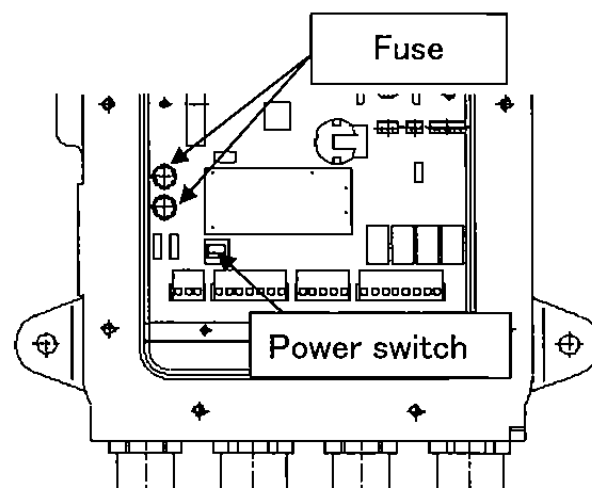

- (4) Supply the power source and confirm that the analyzer works in normal.

4-3. Treatment for storage or long-time shutdown

- (1) When FI-800 is not used for a long time, remove the measuring gas (especially solvent gases and vapors) inside pipings by blowing the fresh air or nitrogen.

- (2) Storage conditions

Temperature : -10~+40°C

Humidity : 30~80%R.H.

Environment : Places of low temperature change.

Places where water vapor does not condense.

4-4. Recommendable spare parts list

No.	Description	Inspection interval	Replacement interval	Q'ty/set
1	Sealing packing (Non-gas contact part)	1 year	7~8 years	1 set
2	Sealing packing (Gas contact part)	1 year	2~4 years	1set
3	Interferometric sensor	1 year	5~8 years	1 pce
4	Circuit board (Display)	-	5~6 years	1 pce
5	Circuit board (MAIN)	-	7~8 years	1 pce
6	Fuse(2A)	-	8 years	2 pcs
7	Flowmeter ass'y (Including low flow sensor)	1 year	7~8 years	2 sets

- * 1. The replacement interval will change depending on operating conditions and it does not mean the guarantee period. Replacement interval may change from inspection results.
- * 2. Material of sealing packing to be used for gas contact part will change according to the kind of measuring gas.
- * 3. Replacement of printed circuit board is required due to the deterioration of capacitors, etc.
- * 4. For assembled unit and circuit board, use pre-adjusted one.
- * 5. The flowmeter ass'y includes the low flow sensor.

5. Trouble shooting

This trouble shooting does not cover all causes of troubles. They are shown main troubles simply to assist studying of causes.

Symptoms	Causes	Treatment
Power is not supplied	<ul style="list-style-type: none"> Correct power source is not supplied 	<ul style="list-style-type: none"> Supply the rated AC power source
	<ul style="list-style-type: none"> Power switch inside analyzer is not turned ON. Fuse is disconnected. 	<ul style="list-style-type: none"> Put the power switch inside analyzer to ON. Replace the fuse with rated one.
	<ul style="list-style-type: none"> Reference gas calibration was done incorrectly. 	<ul style="list-style-type: none"> Supply reference gas from GAS IN and make REF CAL after reading gets stable.
Indication value is not correct	<ul style="list-style-type: none"> Other Gas (not measuring gas, nor reference gas) is contained. 	<ul style="list-style-type: none"> This analyzer cannot measure the gas correctly if other gas is contained.
	<ul style="list-style-type: none"> Water vapor is condensated in piping and measuring gas is melted in condensated water. 	<ul style="list-style-type: none"> Change the installation place of this analyzer(including external pipings) to warm indoor and avoid to condensate water vapor inside pipings. High humidity gas which will be condensated in room temperature level cannot be measured with this analyzer.
	<ul style="list-style-type: none"> Measuring gas (especially solvent) is condensated (liquefied) in a line of piping. 	<ul style="list-style-type: none"> Change the installation place of this analyzer(including external pipings) to warm indoor and avoid to condensate water vapor inside pipings. High humidity gas which will be condensated in room temperature level cannot be measured with this analyzer.

6. Definition of word

The definition of word to be used in this manual.

Measuring gas	Target gas to measure in sample gas
Base gas	Remaining gas excluding measuring gas in sample gas.
Reference gas	The gas to be used as the basic standard gas to measure gas concentration. Normally the base gas is used as reference gas.
Reference gas calibration (REF CAL.)	Adjusting work of reading when reference gas concentration is measured.

The definition of word to be used in specification sheet.

Vol %	This is the unit shown by percentage for how much a specific substances(or gas) in a volume is occupied in that volume.
p p m	This is the unit showing a volume at a part per million. (1 vol% = 10,000ppm)
% LEL	This is the unit to define the lower explosive limit of combustible gas as 100%
mg/L	This is the unit showing a weight in 1 liter of objective gas for measurement. The value is based on 101.3kPa at 20°C.
MJ/m3 Gross	This is the unit of calorie and is shown as Gross Corific Value 0°C. The Gross Calorific Value 0°C is a unit of calorie commonly used in city gas companies, which shows the generating calorie when 1m3 gas is made perfect combustion at normal condition(0°C, 1 atm). The gas combustion produces water vapour, but the Gross Calorific Value applies the one adding the calorie of water vapour (latent heat)
MJ/m3 Net	This is the unit of calorie and is shown as Net Corific Value 0°C. The Net Calorific Value 0°C is a unit of calorie commonly used in city gas companies, which shows the generating calorie when 1m3 gas is made perfect combustion at normal condition (0°C, atm). The gas combustion produces water vapour, but the Net Calorific Value applies the one adding the calorie of water vapour (latent heat)
	Gross calorific value = Net calorific value + latent heat

7. Scrap of the product

This analyzer does not employ harmful substances(materials) for environment.

Treat it in accordance with the local regulations when scrap this analyzer.

8. Product specifications

8-1 Standard specifications

Model	FI-800
Measuring principle	Fourier analysis, combined wave length optical interferometric method.
Measuring method	Sample drawing type by external sampling unit.
Response time	Within 30 sec. to get 90% of concentration (In case of 300 ± 25 ml/min gas supply)
Analog outputs	4~20mADC(Current throw type), into 300Ω impedance max.
Concentration display	Digital LCD display
Alarm outputs	Relay contact (a-contact for each AL1 and AL2), rated 1A at 125VAC/30VDC (Resistive load).
Self-diagnostic function	Low sample flow, decrease of light amount for interferometric light source, decrease of interferometer contrast.
Power requirement	100VAC $\pm 10\%$ ~220VAC $\pm 10\%$, 50/60Hz, max 8VA
Operating temp. & humidity	$-10^{\circ}\text{C} \sim +40^{\circ}\text{C}$, below 80%RH(Condensing gas inside FI-800 is not possible)
Outer dimensions	Approx. 220(W) x 332(H) x 122(D)mm
Weight	Approx 16Kg.
Structure	Flame-proof Exd II B+H2T4

* Measuring gas and range are shown in attached 「Specifications for measuring gas」.

8-2 Standard accessories

- Control key (1 pce.)
- Specifications for measuring gas(1 sheet)
- Operating instruction manual(1 sheet)
- Installation work manual(1 sheet)